

LeadingEdge

Product Sizes, Options and Configuration

Jan 2013 v1.1

ABOUT THIS DOCUMENT

This document gives all the required information to plan and select products for a LeadingEdge system solution.

You should refer to this information with the support of your dealer to ensure you get the correct solution for your requirements. Your dealer will also advise you with upgrade path options, the performance choices available to you and the optimum way of achieving best value for money. This will include appropriate integration with the other components in your system and your room acoustics.

Part 1. Platforms, racks and mini-panels. Line drawings plus tabulated description and sizes. Also includes an assembly summary and technology summary of the platforms.

Part 2. Acoustic panels. Line drawings plus tabulated description and sizes. Also includes an assembly summary of the 'D' panels.

Part 1. Platforms and Racks. Product descriptions and size options

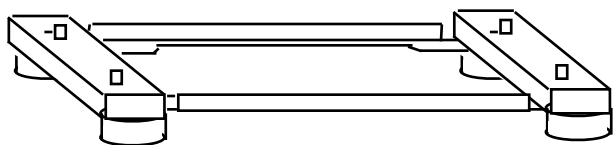
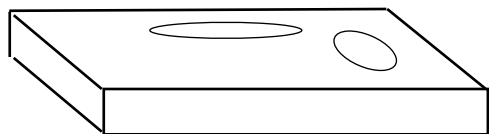
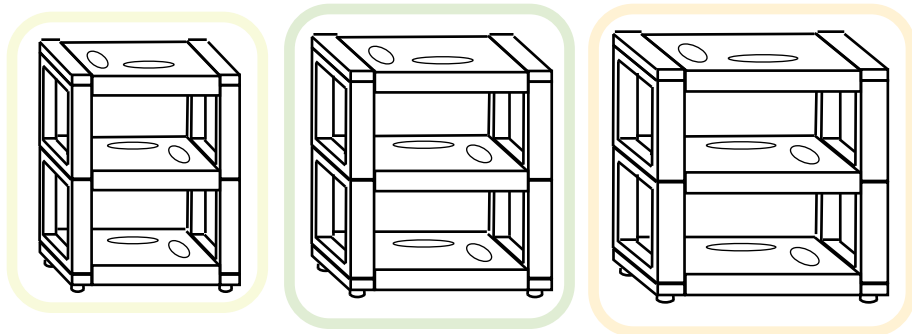

platform and racks – size selection	rack system	footprint (wxd)	max size electronics (wxd)
<p>There are 3 fundamental size solutions. Choose requirement for size of electronics and floor footprint then use colour coding for selection of parts.</p> <p>See 'racks' to determine shelf height options.</p>	rack system small	556x360	430x360
	rack system medium	616x410	490x410
	rack system large	816x530	650x530

coupling tripod and two decoupling cones (set)	options	product ref
<p>Tripod high-carbon steel for correct impedance matching. Decoupling cones are aluminium. Both with mini acoustic labyrinth for resonance reduction.</p>	35 mm height	CDS1

standard platform	options	product ref
<p>Two stainless steel inserts and acoustic labyrinth, EMI absorption, micro-hole panel under, stop-choc isolating feet with adjusters. Standard finishes - oak or cherry.</p>	430x360x63	PL1
	490x410x63	PL2
	650x530x63	PL3

base	options	product ref
<p>Wood side members, steel cross-struts. Supplied with two compliant separator pieces.</p> <p>Includes set of 4 large isolating feet.</p> <p>Standard finishes - oak or cherry.</p>	556x360x30	BR1
	616x410x30	BR2
	816x530x30	BR3

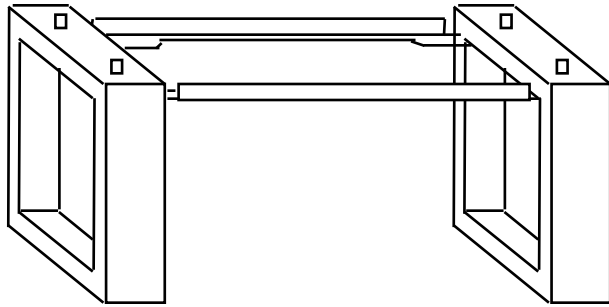

racks	options (wxdxh)	product ref
Wood side members, steel cross-struts. Supplied with two compliant separator pieces. Standard finishes - oak or cherry. Three height options for each format size - 240mm 310mm 380mm max useable height between each shelf layer - 180mm 250mm 320mm allow 35mm for coupler set.	556x360x240	R1
	556x360x310	R2
	556x360x380	R3
	616x410x240	R4
	616x410x310	R5
	616x410x380	R6
	816x530x240	R7
	816x530x310	R8
	816x530x380	R9



shoulder caps (pair)	options	product ref
Wood side pieces to finish top of rack assembly. Standard finishes - oak or cherry.	360x60x30	SC1
	410x60x30	SC2
	530x80x30	SC3

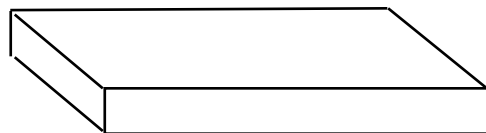

top cover	options (wxdxh)	product ref
Same build as a platform but no stainless steel inserts and no labyrinth. But still contains EMI absorption, micro-hole panel under and stop-choc isolating feet with adjusters. Standard finishes - oak or cherry.	430x360x63	TC1
	490x410x63	TC2
	650x530x63	TC3

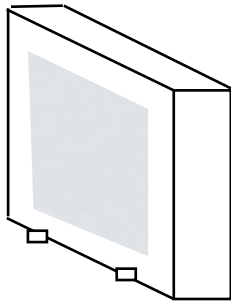

mini-panels	options (wxhxd)	product ref
<p>Micro-hole surface on both sides. EMI absorptive layer within. Standard finishes - oak or cherry.</p> <p>Three height options for each format size - 153mm, 223mm and 293mm.</p> <p>Includes feet.</p>	236x153x40	MP1 (use with R1)
	236x223x40	MP2 (use with R2)
	236x293x40	MP3 (use with R3)
	310x153x40	MP4 (use with R4)
	310x223x40	MP5 (use with R5)
	310x293x40	MP6 (use with R6)
	430x153x40	MP7 (use with R7)
	430x223x40	MP8 (use with R8)
	430x293x40	MP9 (use with R9)

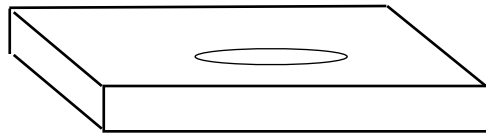

amp platform - floor standing	options (wxdxh)	product ref
<p>Single stainless steel insert and double-layer acoustic labyrinth plus EMI absorption. No micro-hole panel under.</p> <p>Includes set of 4 large isolating feet.</p> <p>Standard finishes - oak or cherry</p>	500x500x63	AP1

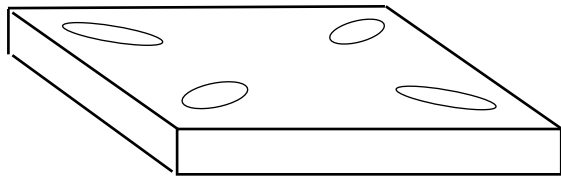

speaker platform - floor standing	options (wxdxh)	product ref
<p>Four stainless steel insert and double-layer acoustic labyrinth plus EMI absorption. No micro-hole panel under.</p> <p>Includes set of 4 large isolating feet.</p> <p>Standard finishes - oak or cherry</p>	380x380x63	SP1
	500x500x63	SP2

Platforms, racks and mini-panels - assembly concept.
See separate assembly instructions for full details
(including amp and speaker platforms).

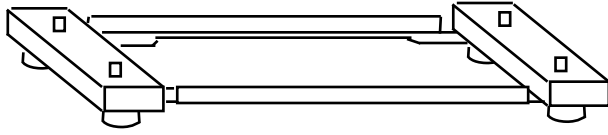

1. Fit large stop-choc feet then locate the base frame in the exact floor position required. level by adjusting feet.

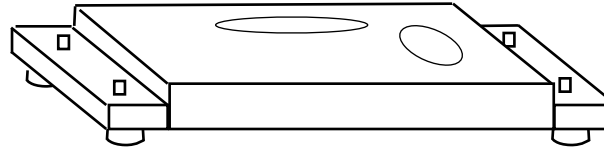

2. Position first platform onto base frame.

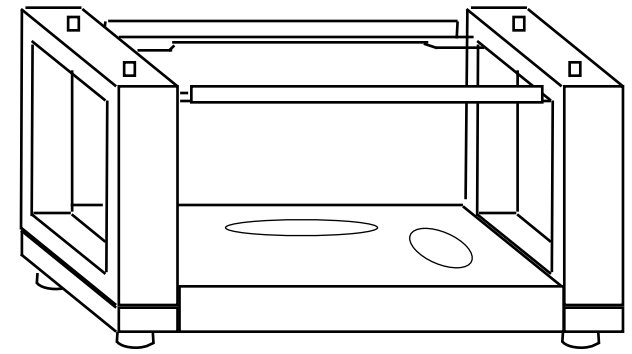

3. Carefully place first rack frame into position over the base frame. Remember to use 2 separator pieces.

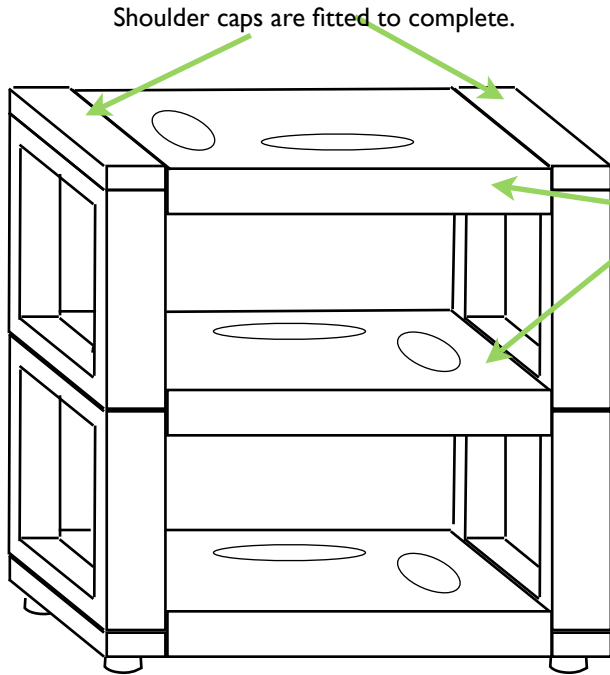

Shoulder caps are fitted to complete.

Platforms can be installed either way around to optimise position of inserts/coupler.

Level each platform individually

4. Continue to build the stack by repeating the process.

An optional third rack is added and a top cover is used to completes the EMI and airborne vibration protection for the component in the shelf space below

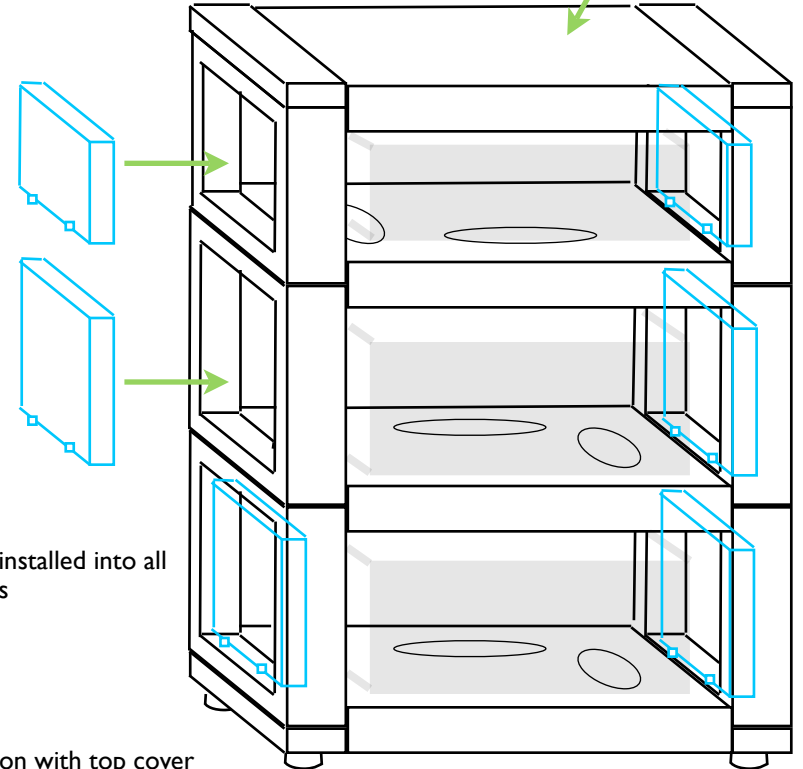

Mini-panels installed into all frame spaces

5. Ultimate configuration with top cover and mini-panels

Technology summary – coupling tripod/decoupling cones and platforms.

This is a schematic cross section showing all the main features internally within the LE platform.

Note that when used with the LE rack system, there is no contact between the rack and the platform, other than through the stop-choc feet. Also, the open sub-frame of the rack leaves the lower micro-perforation panel fully exposed to absorb acoustics from the air space below.

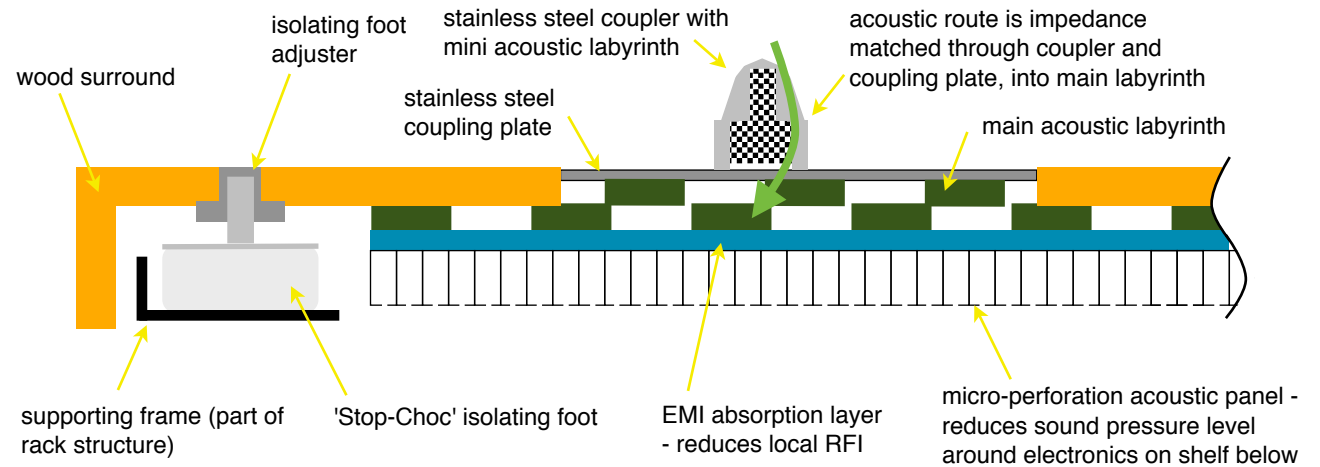

Decoupling cones positioned to best support the component

Coupling tripod can be used on either one of the steel plates.

Small hole in each corner for height adjustment and levelling

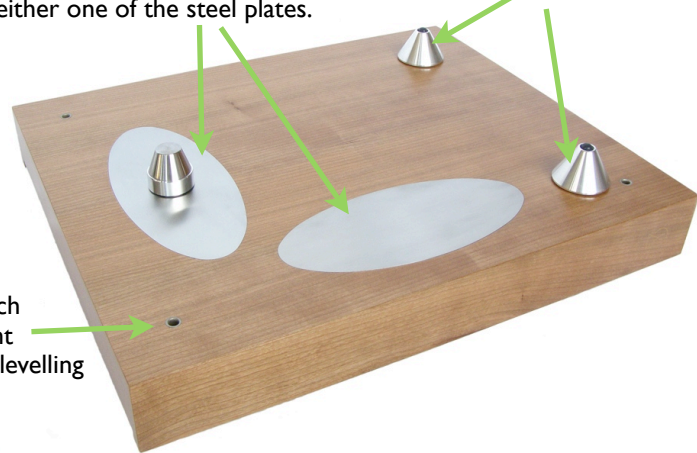

Decoupling cones have rubber top and bottom and have internal labyrinth to reduce resonance



Coupling tripod has steel top, and 3 steel feet on the bottom to minimise acoustic impedance between player chassis and steel plate on platform. Inside coupling tripod is a mini acoustic labyrinth

Decoupling cones

Player raised off its own feet

Coupling tripod

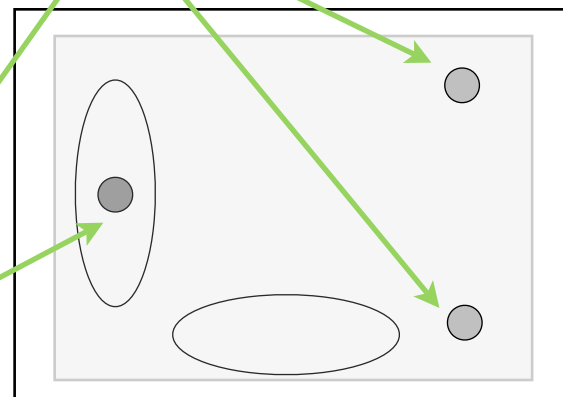

Part 2.

Acoustic Panels. Product descriptions and size options.

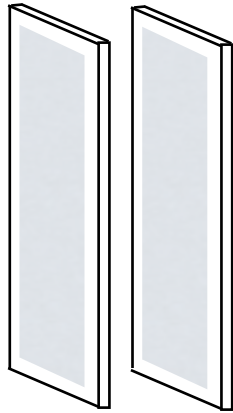

sold as a pair

flat acoustic panel single sided (pair) - wall/ceiling mount	options (wxh)	product ref
Flat micro-hole acoustic panel. Micro-hole surface on one side for wall/ceiling mount (light weight). Standard finishes - oak or cherry. Note: these panels do not have enough structural strength for free-standing use.	600x800	FP1
	600x1100	FP2
	600x1600	FP3

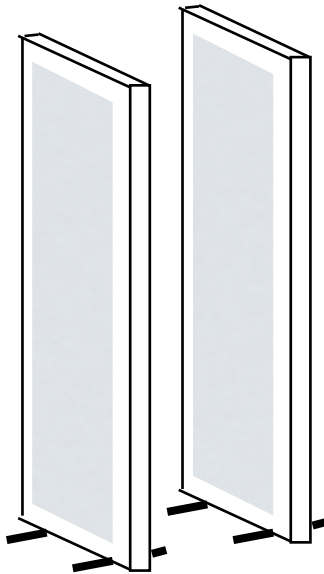

sold as a pair

flat acoustic panel double sided (pair) - free-standing	options (wxh)	product ref
Flat micro-hole acoustic panel. Micro-hole surface on both sides for free-standing use. Supplied with feet and in pairs. Standard finishes - oak or cherry.	600x800	FP4
	600x1100	FP5
	600x1600	FP6

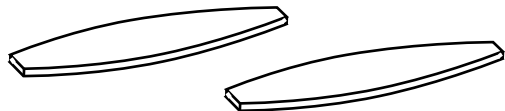
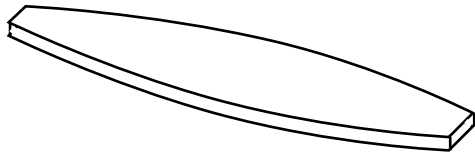
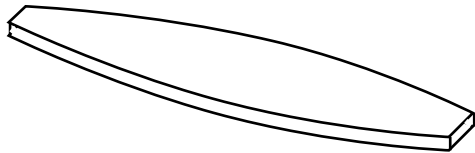
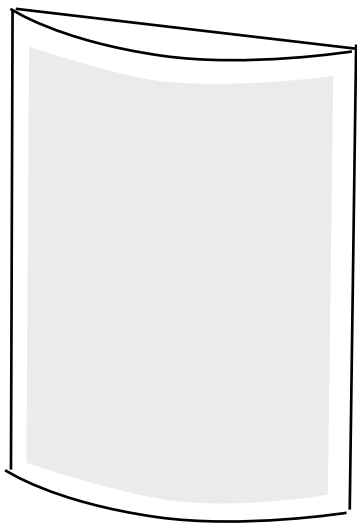

curved acoustic panel ('D' panel) - single sided	options (wxh)	product ref
Curved front with micro-hole acoustic surface. Plain/flat rear surface. Can be used back-to-back in pairs for free-standing use or singly for wall/ceiling mounting. Standard finishes - oak or cherry.	600x800	DP1
	600x1100	DP2
	900x800	DP3
	900x1100	DP4
	1200x800	DP5
	1200x1100	DP6

Double 'D' panel top cover	options	product ref
Top cover for use when 2 'D' panels are used back-to-back. Finished in grey.	620x170x20	DPT1 (use with DP1/2)
	920x215x20	DPT2 (use with DP3/4)
	1220x270x20	DPT3 (use with DP5/6)

D' panel - quad stack spacer	options (lxwxh)	product ref
Spacer for use when 4 'D' panels are stacked. Finished in grey.	620x170x20	DPT1 (use with DP1/2)
	920x215x20	DPT2 (use with DP3/4)
	1220x270x20	DPT3 (use with DP5/6)

Double 'D' panel feet - pair	options	ref
Feet for use when 2 'D' panels are used back-to-back and free-standing. Finished in grey.	500x100x24	DPF1

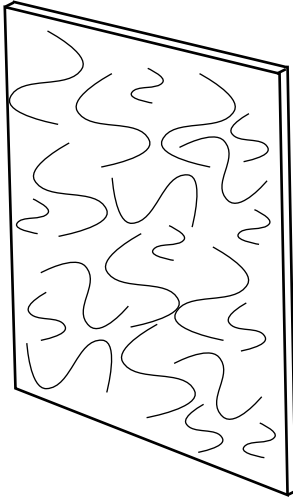

3-D diffuser panel single sided	options (wxhxd)	product ref
Three-dimensional diffuser based on spline mathematics. Plain/flat rear surface for wall/ceiling mounting. Standard finishes - white or grey.	1230x1230x200	3DP1

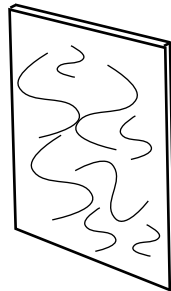

3-D diffuser panel single sided	options (wxhxd)	product ref
Three-dimensional diffuser based on spline mathematics. Plain/flat rear surface for wall/ceiling mounting. Standard finishes - white or grey.	1230x1230x200	3DP2

'D' panel stack - assembly concept. See separate assembly instructions for full details.

Note: this process requires two persons

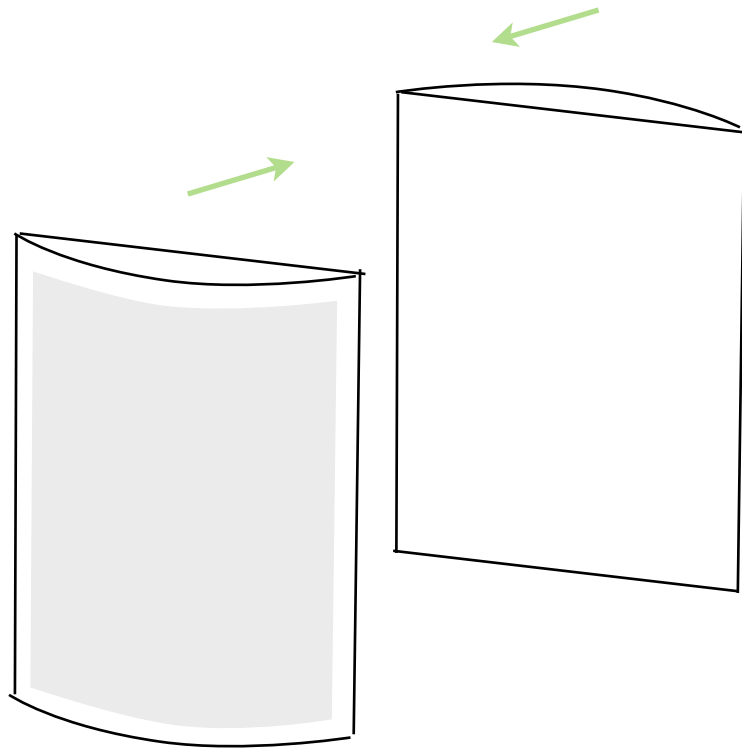

1. Place first two 'D' panels back-to-back

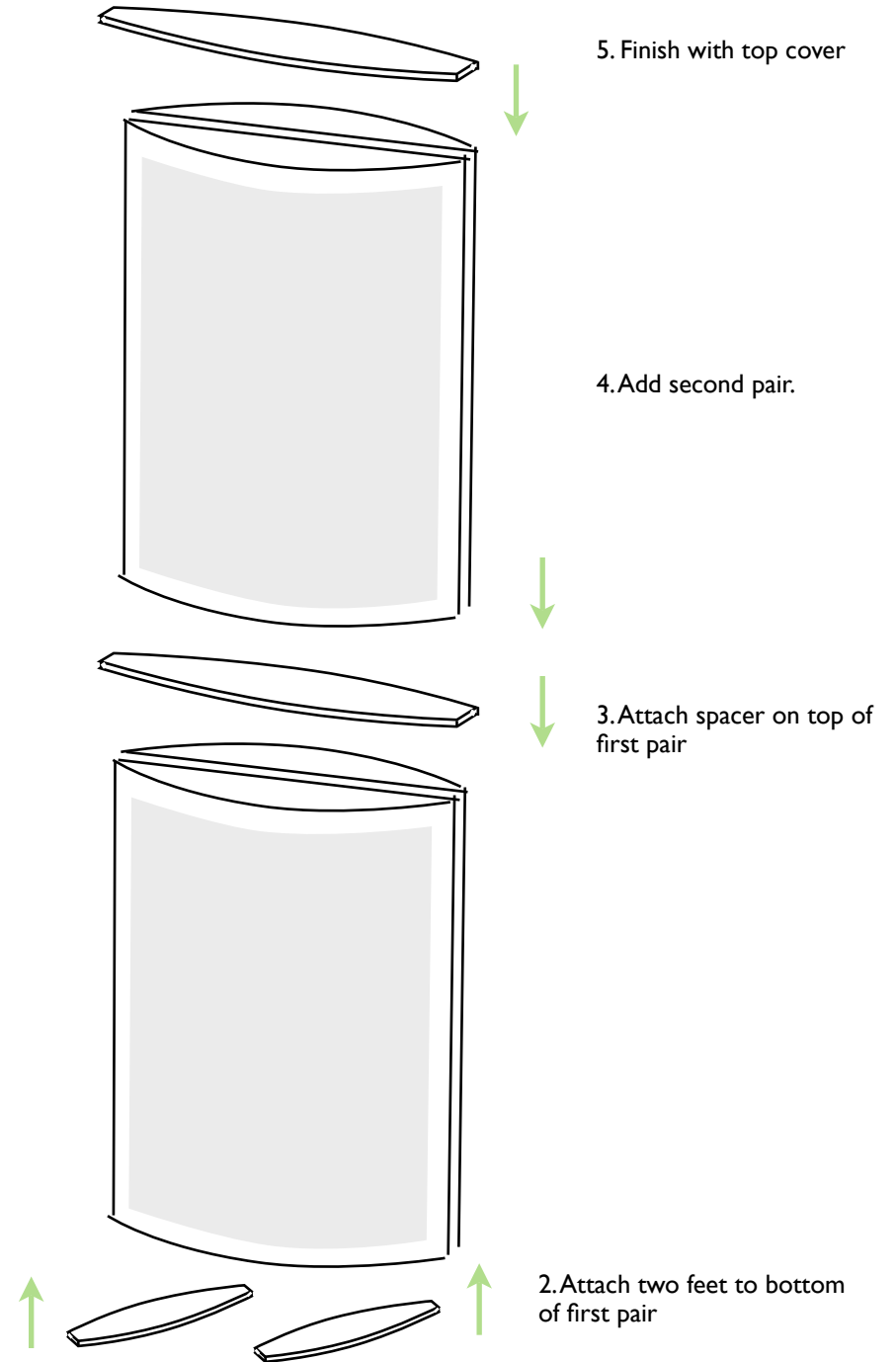

5. Finish with top cover

4. Add second pair.



3. Attach spacer on top of first pair



2. Attach two feet to bottom of first pair